

AC Axial Fan 120x120x25mm(Ver.A)

■ 尺寸图 (DIMENSION DRAWING)

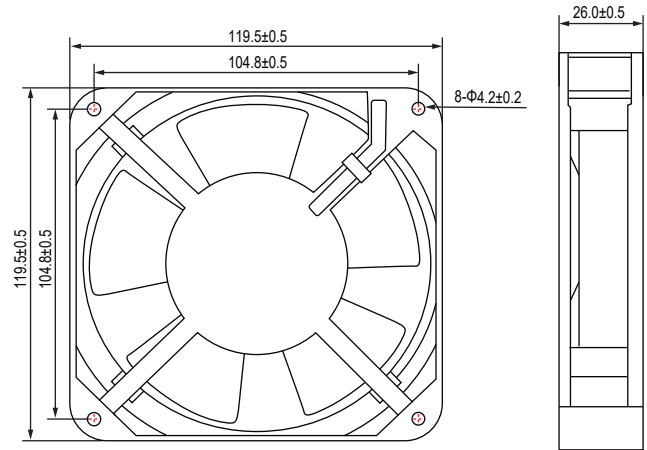

Unit:mm

- * 轴承类型:滚珠轴承 (Bearing type:2-ball)
- * 材料(Material):
框(Frame):铝合金Aluminum Alloy
扇叶(Impeller):PBT(UL94V-0)
- * 引线(Lead wire):
UL1430 AWG #22(Optional)
- * 马达(Motor):罩极马达Shaded pole
- * 保护(Protection): Impedance protection
- * 重量(Weight):320g

■ 风压&风量曲线图 P and Q CURVE

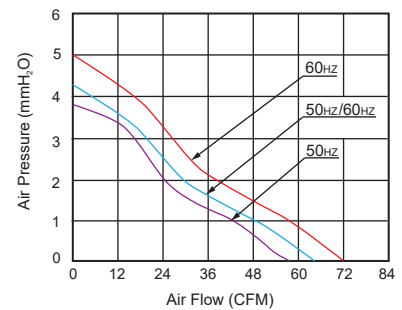

型号 Model	轴承类型 Bearing Type	电压 Voltage	频率 Frequency	电流 Current	功率 Input Power	转速 Speed	风量 Air Flow	风压 Static Pressure	噪音 Noise Level
		VAC	Hz	Amp	Watt	RPM	CFM	MM-H ₂ O	dBA
CC120A10L(T)	2-Ball	100-120	50/60	0.16/0.15	17.0/15.0	2200/2400	58/63	3.8/4.2	35/37
CC120A20L(T)	2-Ball	220-240	50/60	0.07/0.06	17.0/15.0	2200/2400	58/63	3.8/4.2	35/37
CC120A10L(T)	2-Ball	100-120	50/60	0.18/0.14	14.0/11.0	2400/2800	63/72	4.2/5.0	37/40
CC120A20L(T)	2-Ball	220-240	50/60	0.09/0.07	14.0/11.0	2400/2800	63/72	4.2/5.0	37/40

- * 以上为额定电压下的常规参数(All readings are typical values at rated voltage)
- * 规格如有变动不另行通知(Specifications are subjected to change without prior notice)