

DC Blower Fan 80x75x10mm

■ 尺寸图 (DIMENSION DRAWING)

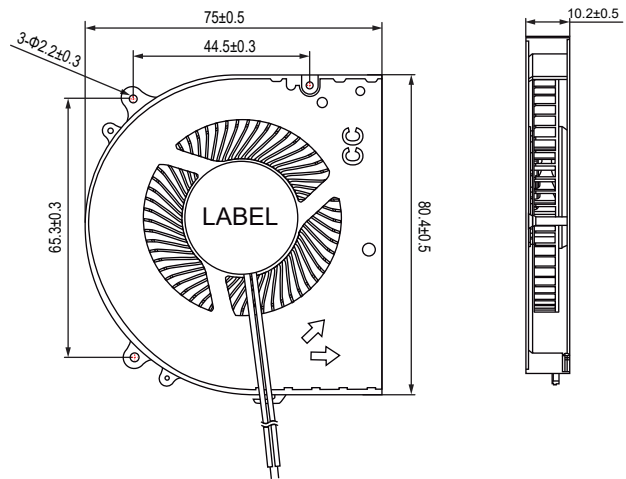

Unit:mm

■ 风压&风量曲线图 P and Q CURVE

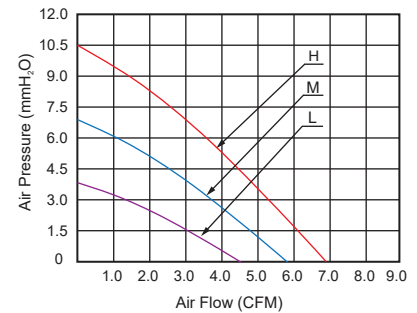

- * 轴承类型: 双滚珠, 流体动压, 液压
(Bearing type: 2-Ball, FDB, Hydraulic)
- * 材料(Material):
扇叶(Impeller): LCP
框(Frame): SECC
- * 引线(Lead wire):
UL1571 AWG #28 or equivalent
红色线正级 Red Wire Positive (+)
黑色线负级 Black Wire Negative (-)
- * 可选择增加风扇功能(Functions are optional)
- * 重量(Weight): 50g

型号 Model	轴承类型 Bearing Type	电压 Rated Voltage	电压范围 Operation Voltage	电流 Current	功率 Input Power	转速 Speed	风量 Air Flow	风压 Static Pressure	噪音 Noise Level
		VDC	VDC	Amp	Watt	RPM	CFM	MM-H ₂ O	dBA
BF8010L05D	2-Ball	5V	4.5~5.5	0.09	0.45	2,000±10%	4.40	4.00	19.0
BF8010L05S3	FDB								
BF8010L05SH	Hydraulic								
BF8010M05D	2-Ball	5V	4.5~5.5	0.16	0.80	2,500±10%	5.60	6.80	23.5
BF8010M05S3	FDB								
BF8010M05SH	Hydraulic								
BF8010H05D	2-Ball	5V	4.5~5.5	0.29	1.45	3,000±10%	6.80	10.5	30.0
BF8010H05S3	FDB								
BF8010H05SH	Hydraulic								
BF8010L12D	2-Ball	12V	10.8~13.2	0.04	0.48	2,000±10%	4.40	4.00	19.0
BF8010L12S3	FDB								
BF8010L12SH	Hydraulic								
BF8010M12D	2-Ball	12V	10.8~13.2	0.07	0.84	2,500±10%	5.60	6.80	23.5
BF8010M12S3	FDB								
BF8010M12SH	Hydraulic								
BF8010H12D	2-Ball	12V	10.8~13.2	0.15	1.80	3,000±10%	6.80	10.5	30.0
BF8010H12S3	FDB								
BF8010H12SH	Hydraulic								

- * 以上为额定电压下的常规参数(All readings are typical values at rated voltage)
- * 规格如有变动不另行通知(Specifications are subjected to change without prior notice)