

Frameless Fan Φ36x10mm

■ 尺寸图 (DIMENSION DRAWING)

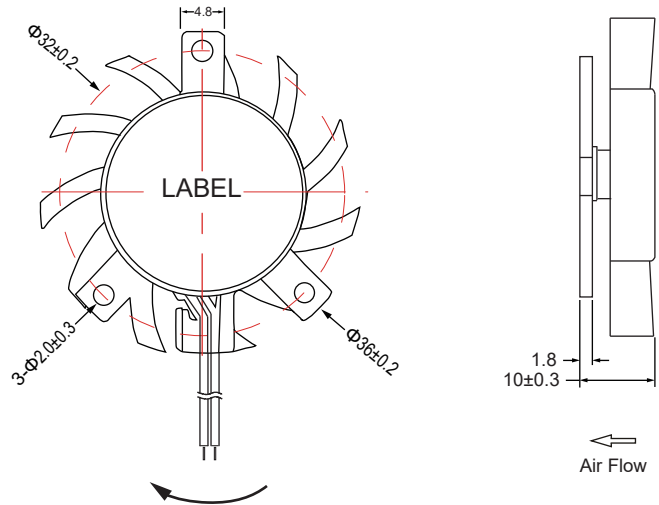

Unit:mm

■ 风压&风量曲线图 P and Q CURVE

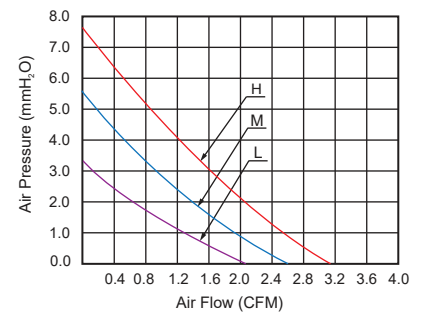

- * 轴承类型: 含油轴承, 双滚珠轴承 (Bearing type:Sleeve,2-Ball)
- * 材料(Material):
框叶(Frame & Impeler):PBT
- * 引线(Lead wire):
UL1061 AWG #26 or equivalent
红色线正级 Red Wire Positive (+)
黑色线负级 Black Wire Negative (-)
- * 可选择增加风扇功能(Functions are optional)
- * 重量(Weight):8.0g

型号 Model	轴承类型 Bearing Type	风扇类型 Fan Type	版本 Version	电压 Rated Voltage	电流 Current	转速 Speed	风量 Air Flow	风压 Static Pressure	噪音 Noise Level
				VDC	Amp	RPM	CFM	MM-H ₂ O	dBA
CC4010L05S	Sleeve	Frameless	-C	5V	0.10	4,000±10%	2.00	3.20	22.0
CC4010L05D	2-Ball								
CC4010M05S	Sleeve	Frameless	-C	5V	0.15	5,000±10%	2.50	5.50	26.0
CC4010M05D	2-Ball								
CC4010H05S	Sleeve	Frameless	-C	5V	0.28	6,000±10%	3.00	7.50	31.0
CC4010H05D	2-Ball								
CC4010L12S	Sleeve	Frameless	-C	12V	0.05	4,000±10%	2.00	3.20	22.0
CC4010L12D	2-Ball								
CC4010M12S	Sleeve	Frameless	-C	12V	0.10	5,000±10%	2.50	5.50	26.0
CC4010M12D	2-Ball								
CC4010H12S	Sleeve	Frameless	-C	12V	0.20	6,000±10%	3.00	7.50	31.0
CC4010H12D	2-Ball								

- * 以上为额定电压下的常规参数(All readings are typical values at rated voltage)
- * 规格如有变动不另行通知(Specifications are subjected to change without prior notice)