

## Frameless Fan $\Phi 46 \times 10 \text{mm}$

### ■ 尺寸图 (DIMENSION DRAWING)

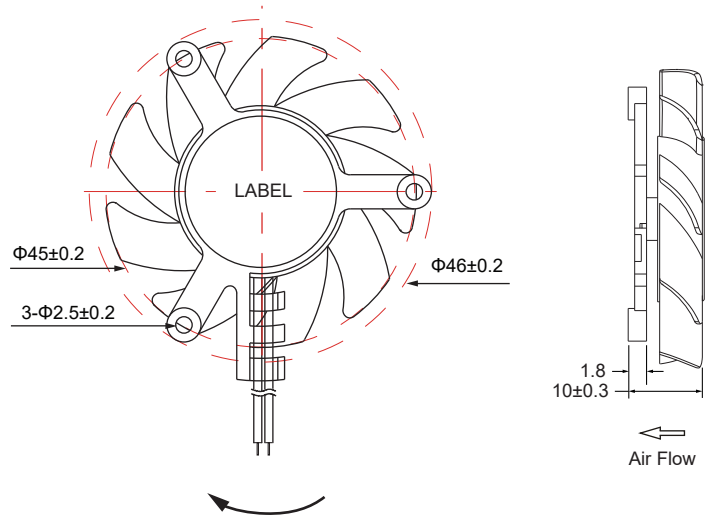

Unit:mm

### ■ 风压&风量曲线图 P and Q CURVE

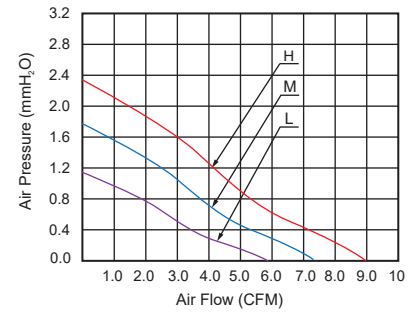

- \* 轴承类型: 含油轴承, 双滚珠轴承 (Bearing type:Sleeve,2-Ball)
- \* 材料(Material):  
框叶(Frame & Impeller):PBT
- \* 引线(Lead wire):  
UL1061 AWG #26 or equivalent  
红色线正级 Red Wire Positive (+)  
黑色线负级 Black Wire Negative (-)
- \* 可选择增加风扇功能(Functions are optional)
- \* 重量(Weight):11.0g

型号 Model	轴承类型 Bearing Type	风扇类型 Fan Type	版本 Version	电压 Rated Voltage	电流 Current	转速 Speed	风量 Air Flow	风压 Static Pressure	噪音 Noise Level
				VDC	Amp	RPM	CFM	MM-H <sub>2</sub> O	dBA
CC5010L12S	Sleeve	Frameless	-A	12V	0.05	3,500±10%	5.90	1.10	20.0
CC5010L12D	2-Ball								
CC5010M12S	Sleeve	Frameless	-A	12V	0.09	4,500±10%	7.30	1.80	28.0
CC5010M12D	2-Ball								
CC5010H12S	Sleeve	Frameless	-A	12V	0.17	5,500±10%	9.00	2.30	32.0
CC5010H12D	2-Ball								

- \* 以上为额定电压下的常规参数(All readings are typical values at rated voltage)
- \* 规格如有变动不另行通知(Specifications are subjected to change without prior notice)