

■ 一般规格 (General Specifications)

- * 风扇轴承类型: 液压轴承
(Fan bearing type: Hydraulic)
- * 风扇材料(Material):
扇叶(Impeller): PBT
框(Housing): PBT & SECC
- * 散热器材质: 铝
(Heatsink: Aluminium)
- * 引线(Lead wire):
UL1571 AWG #28 or equivalent
红色线正级 Red Wire Positive (+)
黑色线负级 Black Wire Negative (-)
绿色线FG信号 Green Wire Signal (FG)
蓝色线PWM功能 Blue Wire (PWM)
- * 风扇功能(Fan Functions): FG+PWM
- * 重量(Weight): 197g

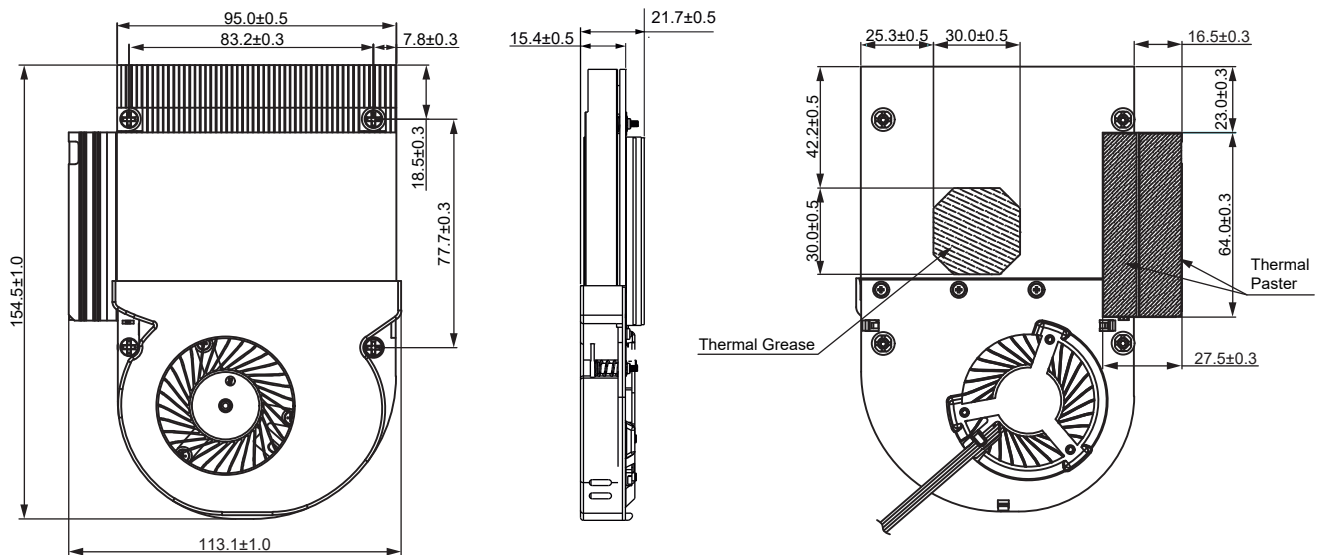

■ 尺寸图 (Dimension Drawing)



■ 风扇参数 (Fan Parameters)

型号 Model	轴承类型 Bearing Type	电压 Rated Voltage	电压范围 Operation Voltage	电流 Current	功率 Input Power	转速 Speed	风量 Air Flow	风压 Static Pressure	噪音 Noise Level
		VDC	VDC	Amp	Watt	RPM	CFM	MM-H ₂ O	dB-A
CC-IPC63	Hydraulic	5V	4.5~5.5	0.50	2.50	3,000±10%	6.94	11.50	35.0

- * 风扇功能可选择(Function is optional)
- * 噪音值为在无响室测试得到的结果, 测试距离1米(Noise is measured in anechoic chamber, one meter from intake side)
- * 以上为额定电压下的常规参数(All readings are typical values at rated voltage)
- * 规格如有变动不另行通知(Specifications are subjected to change without prior notice)