

EC Axial Fan 205x205x72mm

■ 尺寸图 (DIMENSION DRAWING)

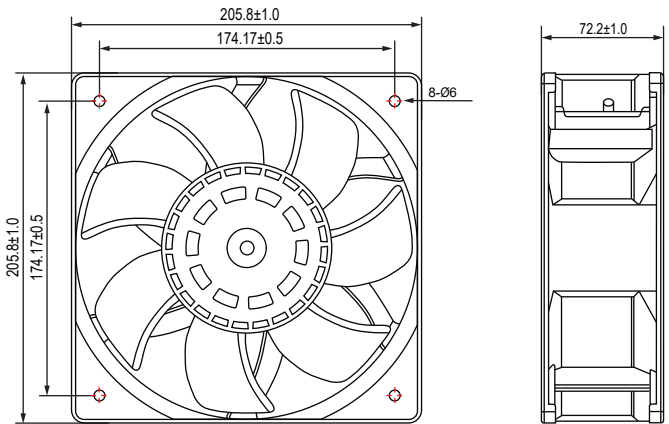

Unit:mm

- * 轴承类型: 滚珠轴承 (Bearing type: 2-ball)
- * 材料 (Material):
框 (Frame): Aluminum Alloy
叶 (Impeller): PBT, UL 94V-0
- * 引线 (Lead wire):
UL1015 AWG #22 (Optional)
- * 重量 (Weight): 2300g

■ 风压&风量曲线图 P and Q CURVE

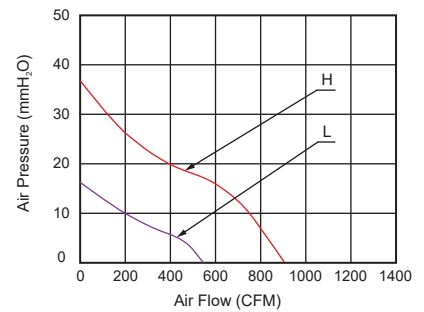

型号 Model	轴承类型 Bearing Type	电压 Rated Voltage	电压范围 Operating Voltage Range	频率 Freq.	功率 Power	转速 Speed	风量 Air Flow	风压 Static Pressure	噪音 Noise Level
		VAC	VAC	Hz	Watt	RPM	CFM	MM-H ₂ O	dBA
CCE20572L1B	2-Ball	110V	80~135	50/60	85.00	2,400±10%	563.0	15.5	61.0
CCE20572L2B	2-Ball	220V	180~265	50/60	85.00				
CCE20572H1B	2-Ball	110V	80~135	50/60	125.00	3,500±10%	880.0	35.7	72.0
CCE20572H2B	2-Ball	220V	180~265	50/60	125.00				

- * 以上为额定电压下的常规参数 (All readings are typical values at rated voltage)
- * 规格如有变动不另行通知 (Specifications are subjected to change without prior notice)