

EC Axial Fan $\Phi 220 \times 60 \text{mm}$

■ 尺寸图 (DIMENSION DRAWING)

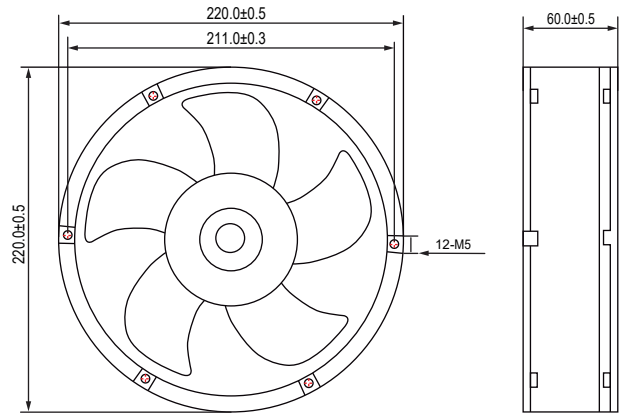

Unit:mm

- * 轴承类型:滚珠轴承
(Bearing type:2-ball)
- * 材料(Material):
框 (Frame):Aluminum Alloy
叶 (Impeller):PBT,UL 94V-0
- * 引线(Lead wire):
UL1015 AWG #22(Optional)
- * 重量(Weight):1500g

■ 风压&风量曲线图 P and Q CURVE

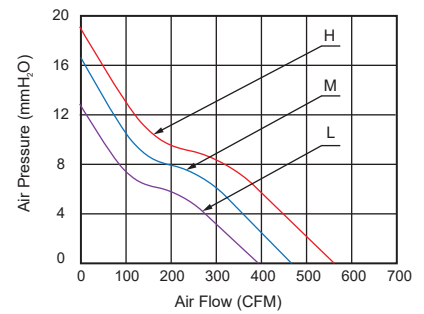

| 型号 Model | 轴承类型 Bearing Type | 电压 Rated Voltage | 电压范围 Operating Voltage Range | 频率 Freq. | 功率 Input Power | 转速 Speed | 风量 Air Flow | 风压 Static Pressure | 噪音 Noise Level |
|-------------|----------------------|---------------------|---------------------------------|-------------|-------------------|-------------|----------------|-----------------------|-------------------|
| | | VAC | VAC | Hz | Watt | RPM | CFM | MM-H ₂ O | dBA |
| CCE20060L1B | 2-Ball | 110V | 80~135 | 50/60 | 42.00 | 2,500±10% | 393.0 | 12.7 | 31.0 |
| CCE20060L2B | 2-Ball | 220V | 180~265 | 50/60 | 42.00 | | | | |
| CCE20060M1B | 2-Ball | 110V | 80~135 | 50/60 | 70.00 | 3,000±10% | 470.0 | 16.1 | 35.0 |
| CCE20060M2B | 2-Ball | 220V | 180~265 | 50/60 | 70.00 | | | | |
| CCE20060H1B | 2-Ball | 110V | 80~135 | 50/60 | 90.00 | 3,500±10% | 553.0 | 18.8 | 37.5 |
| CCE20060H1B | 2-Ball | 220V | 180~265 | 50/60 | 90.00 | | | | |

- * 以上为额定电压下的常规参数(All readings are typical values at rated voltage)
- * 规格如有变动不另行通知(Specifications are subjected to change without prior notice)